

## PNEUMATIC DISCHARGE DEVICE PULSATOR LOOSENING SYSTEM

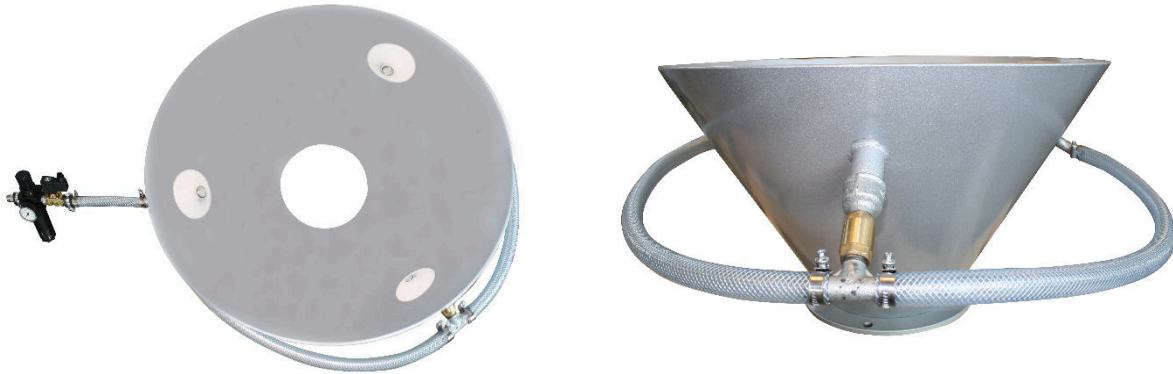

PL3 with ring set, magnet valve, service unit (built into the silo cone)

The pulsator loosening system is used to fluidize lazy flowing, technically dry, non-sticky, powdery products. Use in a series of pulses while discharging material is recommended.

Dosed air fluidizes/ventilates the bulk material and additionally generates resonant, vibrating waves which support the flow of the bulk material. The Fluidisation of bulk product takes place along the silo wall. The pulsator sleeve with double sealing lip and a non-return valve prevents the product from flowing back into the compressed air network. The extremely flat design allows a safe product discharge.

The pulsators are made of stainless steel 1.4305 (AISI 303) with a food-safe sleeve standard design made of silicone Ø 100 mm white or natural (max. 170°C). An EDPM cuff is also available where silicone cannot be used.

- 3, 6 or 9 special pulsators, for installation into silo cone
- Plastic reinforced tube, filter pressure reducing unit, assembled solenoid valve with mounting clamp for installation on silo cone or silo bracket
- The pre cleaned air (max. operating pressure of 5 bar) is connected on site to the strainer with a suitable tube. The air flows through the oil and water separator into the pressure reducing unit which throttles the air pressure to the necessary level. By activating the solenoid valve, the compressed-air flows through the plastic reinforced tube to the check valves, which are located directly in front of the air injectors, to finally fluidize the bulk material.
- With on site mounted maintenance unit
- Simple subsequent installation
- Rugged design
- High temperature range

### Areas of Application

### Details / Explanation

### Advantages

### Construction of a pulsator



Pulsator as an single component

Pulsator with mounting set and mounting cable

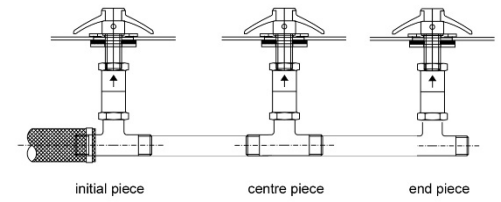
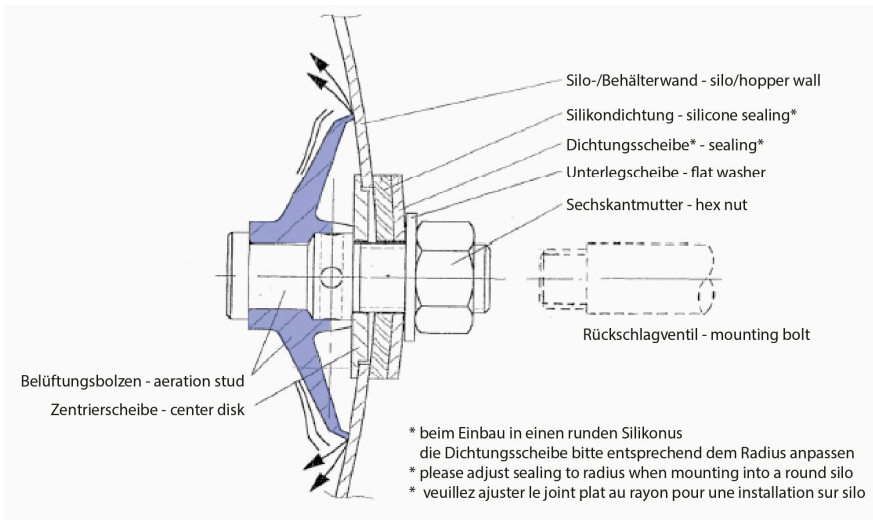

**Construction of a pulsator**

Service unit with 1 solenoid valve / 3 pulsators

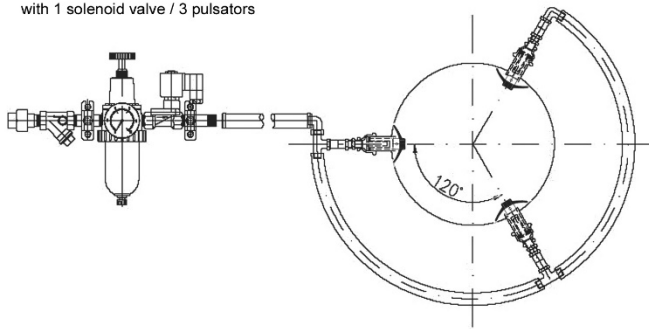

**Scale drawing with 3 pulsators**

Service unit with 2 solenoid valves / 6 pulsators

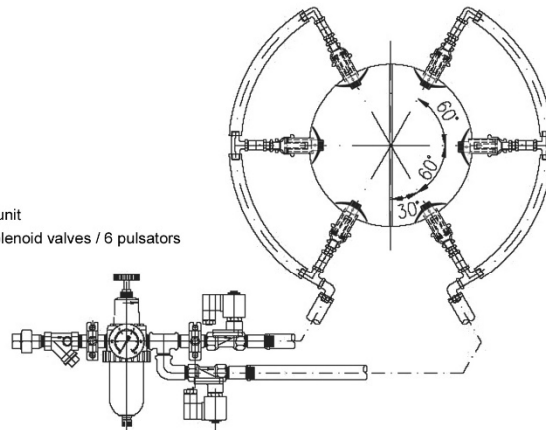

**6 pulsators**

Service unit with 3 solenoid valves / 9 pulsators

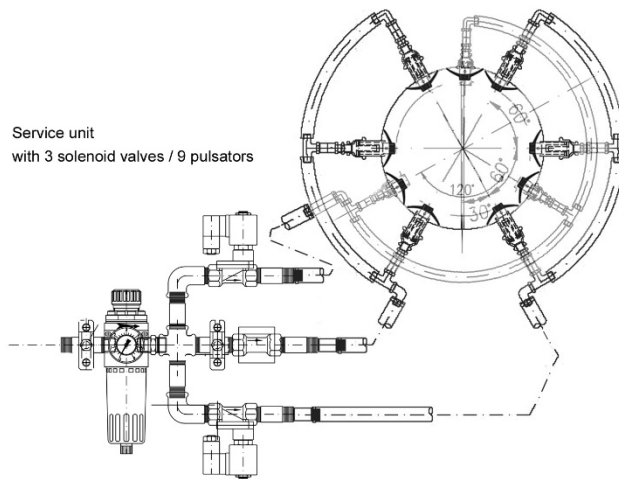

**9 pulsators**

**Technical Data**

Number of pulsator	3	6	9
Air consumption at 1,0 bar timed: 3 sec. on / 7 sec. off	225 Nltr. / min.	450 Nltr. / min.	675 Nltr. / min
Operating pressure	1 – 2,0 bar		
Volume flow per injector	250 ltr./ min.		
Max. temperature strain	80° C, higher temperatures on request		
Number of solenoid valves	1	2	3
Connector	G 1/2"		
Pulse duration time	2-3 sec.		
Break duration time	7-10 sec.		
Air (conditions)	Technical dry, oil and foreign substance free		
Voltage on solenoid valve	24VDC (standard) / 230VAC (option)		

**Physical data air injector**

- Stainless steel 1.4301, AISI 304.
- Operating temperature up to 170° C.

**Material**

**Air and electrical input lead, compressor and fan are not included.**

**Notice**



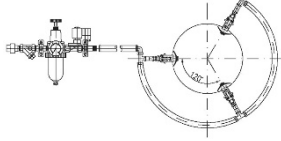
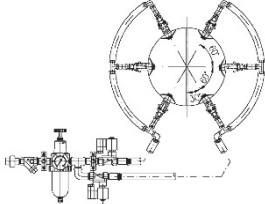
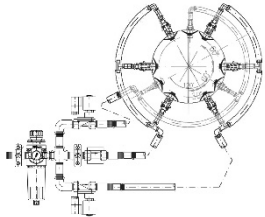

**Air injector incl. ring pipe, service unit, solenoid valve**





Number of pulsator / solenoid valve	3/1	6/2	9/3
Article number	742 10 049	742 10 063	742 10 051
			











**Please do not forget to specify the control voltage (24VDC or 230VAC)!  
Further numbers of injectors on request.**

**Clock relay in plastic body IP 54, 230V 50Hz, for on site installation**

Clock control STL up to 4 solenoid valves	3/1	6/2	9/3	
	Article number			
230V/DC connection voltage	881 10 229			
24V/DC connection voltage	881 10 229-01			

**Equipment / Spare Parts**

	Article number	
Pulsator silicone white	742 10 052	
Pulsator mounting set 4 pieces for subsequent installation, in addition a Mounting cable / pull rope required	742 10 055	
Mounting cable/ pull rope	742 10 056	
Hole saw for subsequent installation pulsators	742 10 058	
End piece	ST0713	
T piece	ST2312	
Tube & T-piece	ST0191 ST2312	
Non-return valve	804 10 002	
Air hose transparent per meter	ST2176-PVC	
Solenoid valve 24V/DC	881 10 130	
Solenoid valve 230V/AC	881 10 087	
Solenoid valve <b>ATEX</b> 24V/DC with 3m cable	881 10 087	

Service unit for air injector loosening system complete, 230V/AC, with 1 solenoid valve	742 20 001	
Service unit for air injector loosening system complete, 24V/DC, with 1 solenoid valve	742 20 002	
Service unit for air injector loosening system complete, 24V/DC <b>ATEX 3D</b> , with 1 solenoid valve	742 20 003	
Service unit for air injector loosening system complete, 230V/AC, with 2 solenoid valves	742 20 004	
Service unit for air injector loosening system complete, 24V/DC, with 2 solenoid valves	742 20 005	
Service unit for air injector loosening system complete, 230V/AC, with 3 solenoid valves 	742 20 006	
Service unit for air injector loosening system complete, 24V/DC, with 3 solenoid valves	742 20 007	
Service unit for air injector loosening system complete, 24V/DC, with 4 solenoid valves	742 20 008	
Service unit for air injector loosening system complete, 24V/DC <b>ATEX 3D</b> , with 2 solenoid valves	742 20 009	

**Additional air fluidisation systems**

